

Blending on Board – innovative engine lubrication management

AUTHORS: **Shamba Jumaine**, Tribology Expert 2-stroke, Services Delivery Management
Markus Zehnder, Innovation Manager 2-stroke, Services Solution Management
Andreas Wiesmann, GM Innovation & Business Development, Services Solution Management



Photo: Courtesy of Maersk Line.

■ Fig. 1 – The Maersk Line's container vessel EDITH MÆRSK with a 14-cylinder Wärtsilä RT-flex96C main engine will be fitted with Blending on Board in 2012.

Blending on Board (BOB) is a new concept developed by Maersk Fluid Technology Inc with whom Wärtsilä has a co-operation agreement for the joint marketing and sales of the system. BOB optimises the overall lubrication performance of large bore diesel engines. It also enhances operational flexibility and independency.

Traditional cylinder and engine lubrication

Two-stroke cross-head diesel engines typically use at least two different oils besides the fuel oil: the general system oil, which serves as the lubricating and cooling oil for engine components; the special cylinder lubricating oil, which lubricates the piston ring/cylinder liner contact; and the servo oil, which in Wärtsilä two-stroke engines is the system oil.

The cylinder lubricating oil is specially formulated with additives to fulfil three main purposes:

- To create a sufficient oil film between the running surfaces of the cylinder liner and the piston rings to minimize friction and wear of the components
- To clean the piston, piston rings, and cylinder liner from deposits, which is

achieved by the special detergency and dispersancy properties of the additives

- To prevent cold corrosion by neutralizing the acidic species created during engine operation. The main acid to be neutralized is the sulphuric acid produced from the sulphur content of the fuel burnt in the engine.

Cylinder lubricating oil is injected into the cylinder via the cylinder lubrication system (on Wärtsilä two-stroke engines, e.g. the CLU-3 or the Pulse Lubrication System). The cylinder lubricating oil and system oil are separated in two-stroke cross-head engines by stuffing boxes.

The system oil usually remains for a long time in the engine as it is consumed in only relatively small quantities. During →

operation, depending on the condition and wear of the components, the oil loses its initial properties and cleanliness. Even though the oil consumption through the stuffing boxes, as well as from leakages and during oil separation is small, topping up of the system oil sump, and in certain cases a complete oil change, is necessary due to the ageing of the oil. Depending on the condition of the engine and the oil treatment plant, the daily system oil consumption is between a few litres and approximately ten litres per cylinder.

Depending on the engine type, design, and cylinder lubricating system type, the recommended feed rate for Wärtsilä two stroke engines under normal engine operating conditions is between 0.8 and 1.1 g/kWh at CMCR. For the latest engine type additions in the portfolio, this feed rate will be further reduced.

In order to match the properties of the commercially available cylinder oil with the sulphur content (S%) of the currently used heavy fuel oil, Wärtsilä recommends in its engine operating instructions that oils with BN70 for sulphur contents >1.5% and BN40 for sulphur contents <1.5%, be used. In addition to these standard oils, other oils with BN levels between BN40 and BN70 are available on the market.

When engines are continuously operated at lower loads below 60% contracted maximum continuous rating (CMCR), and with fuels having high sulphur content (e.g. sulphur content higher than 3% in the HFO with a 70 BN lubricant), the neutralisation performance of the standard cylinder lubricating oil is not sufficient at the same low feed rate. For this reason, Wärtsilä recently recommended feed rate adjustments for different combinations of lubricating oil BN levels and fuel sulphur content. A Technical Bulletin (TB RT-113) was published to communicate this recommendation to customers.

Requirements for flexible operation

Today's requirements in shipping often call for the vessel's main engine to have highly flexible operation capabilities, while at the same time maintaining high reliability. Versatility, in terms of the engine's operational load and different fuel oil qualities, is of paramount importance for operational costs. Furthermore, constraints related to Emission Control Areas and new fuel regulations call for more cylinder lubrication adaptability to ensure reliable piston running.

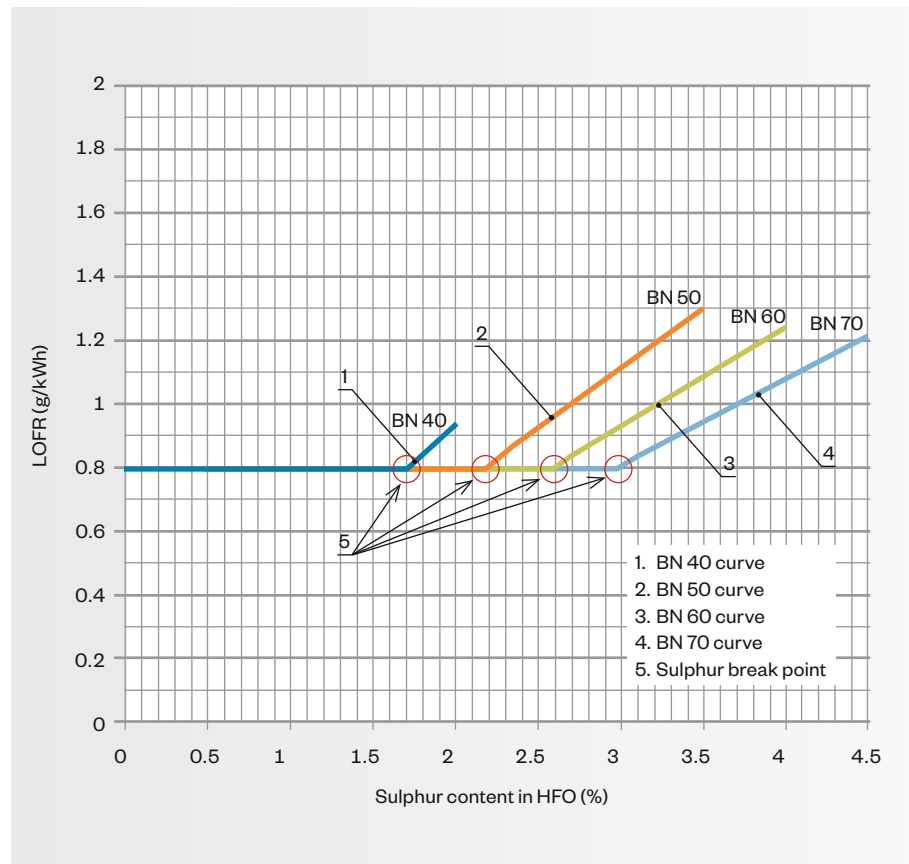

■ Fig. 2 – Recommended feedrate adjustments at loads <60%, based on fuel sulphur content (S%) and cylinder oil in use.

High sulphur fuel, harsh operating conditions, and long-term low or ultra-low load operation require increased cylinder oil performance for neutralisation, detergency and dispersancy. Extended engine operation with very low sulphur fuel, MDO or MGO, is also required.

Operators usually address these conflicting requirements by using two different cylinder oils (typically 40BN and 70BN) – sometimes also with a new in-between BN cylinder oil (typically in the range of 55-60BN) – and a sulphur dependent feed rate adjustment according to the engine manufacturer's recommendation. This enables them to cope with the variability of the fuel's sulphur content, in particular in reduced engine load operation.

These traditional measures are working compromises for operating engines under more or less normal conditions, and in combination with heavy fuel oils having sulphur contents of between 0.8% and 3.5%.

The Blending on Board concept

Looking at the main purposes of cylinder

lubrication – building an optimal oil film for piston running, neutralising sulphuric acid from fuel combustion, and cleaning – a better alternative (both technically and commercially) to the traditional measures would be to maintain the cylinder oil feed rate at the most optimal level under almost all operational conditions, while simultaneously adjusting the cylinder oil's properties to the actual conditions.

This is exactly what is achieved with the innovative Blending on Board concept. It provides a unique, flexible solution to these challenging requirements. The concept is to keep the cylinder oil feed rate constantly low while adjusting the concentration of the additives in the oil. This results in a wide base number range from 40BN to 120BN. Furthermore, it is adapted to the actual heavy fuel oil sulphur content, to other fuel types used in relation to the relevant regulations, and to the engine load pattern.

With a Blending on Board installation, the used system oil is transferred from the main engine, and optionally also the auxiliary engines (up to 10% of the total

The cylinder lubricating oil is blended from used system oil and additives for achieving the required BN level and oil properties.

used oil volume), and is then blended with a specially formulated cylinder oil additive. The result is customized cylinder oil for each vessel's specific operating conditions, thus reducing a vessel's lube oil consumption by 10%-50%, depending on the currently used feed rate. With the now frequent transfer of system oil to the blender, the vessel is able to replenish the engine sump with fresh oil, without any waste oil disposal, which results in a cleaner engine and better engine performance.

Installing the Blending on Board system

The solution has been designed in a modular way in order to allow easy installation. The BOB system consists of a blender with a blender control panel, and an XRF analyzer (either with or without the ability to detect cat fines).

The product names are:

- SEA-Mate® Blender B3000
- SEA-Mate® Analyzer M2000 (without cat fines detection)
- SEA-Mate® Analyzer M3000 (with cat fines detection)

The system is compact enough to be transported through a normal door. Some modifications to the existing piping and tank allocation are necessary, but no new tank installations are required. The Blending on Board system is ABS and Lloyds Register approved.

The **SEA-Mate® Blender** is a compact, robust, reliable and easy-to-use piece of equipment, designed to fit an engine room's environment. It is connected to the "Used System Oil Tank for BOB" and the "Additives Tank" on one side, and the "Blended Cylinder Oil Tank" and/or "Day Tank" on the other side.

The operator onboard enters the following values on the screen of the blender control panel:

- The used system oil's BN level – this can be determined beforehand from the Analyzer
- The additive's BN level – this needs to be entered just once at the beginning, unless a different additive product is purchased at a later stage
- The target BN level for the new batch of blended cylinder oil – the value can be determined from Blending on Board instructions (and in the future will be an integrated function in the blender control panel)
- The amount in tonnes for the new batch of blended cylinder oil. →

The product is based on a blender and an analyzer, which are installed onboard the vessel.

Some modifications to the existing piping and tank allocation will be necessary.



■ Fig. 3 – SEA-Mate® Blender B3000.

■ Fig. 4 – Target BN levels for the blended cylinder oil for different fuel S%.

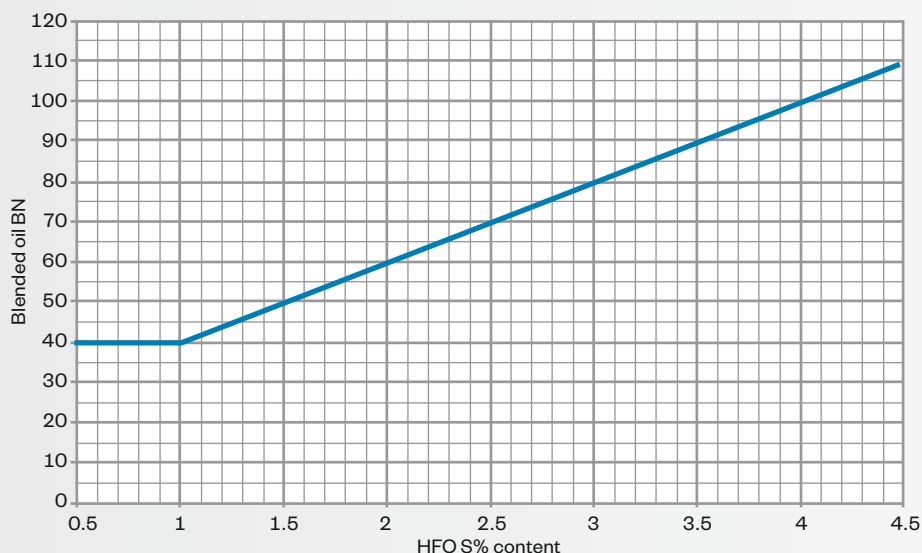



■ Fig. 5 - SEA-Mate® Analyzer M3000.

After pushing the “Start” button, the blender completes the required blending on its own. Optionally, the operator can also set the blender operation on automatic, which will repeat the blending process with the set values, once the blended cylinder oil tank reaches a set minimum level.

The SEA-Mate® Blender B3000 is equipped with all class-required features for safe maritime operation.

The SEA-Mate® Analyzer is an integrated part of the Blending on Board installation. It is an advanced XRF technology based analyzer that provides state-of-the-art onboard or on site analysis capability for lubricants and fuels. It also provides the operator with a whole new level of awareness and knowledge regarding the importance of lubrication oil, engine condition and monitoring. It is designed in a robust way, gives the user clear on-screen guidance and instructions, and provides analysis results within only six minutes.

The analyzer is supplied together with a bar-code reader and all required sample bottles and bar-code labels for sampling locations and bottles. This enables the easy handling of sampling and provides unique management for analysis data. The software offers various possibilities for trending,

reporting, as well as data export.

The SEA-Mate® Analyzer is available in two different versions. The SEA-Mate® M2000 is designed for analyzing lubricants and fuel sulphur only, while the SEA-Mate® M3000 is intended for analyzing both lubricants and fuels, and it includes the detection and measurement of cat fines in the fuel. Besides BN levels of lubricants, various elements can be detected and accurately measured in lubricants and fuels.

The XRF technology enables the detection and measurement of total iron (Fe), which makes the SEA-Mate® Analyzer a unique tool, most especially in monitoring the condition of the cylinder and piston components, as it enables the detection of both abrasive and corrosive wear.

The analyzers were tested in long field tests, and measuring results from the SEA-Mate® Analyzer were compared with results from professional land-based laboratories run from the same samples. The latter comparison showed a very good correlation ($R^2 > 0.95$) between the laboratory results and the SEA-Mate results.

Installation of the Blending on Board system is relatively simple and can be done without interrupting the vessel's commercial operations. After installation of the SEA-Mate®

■ Fig. 6 - The principle of the Blending on Board system.

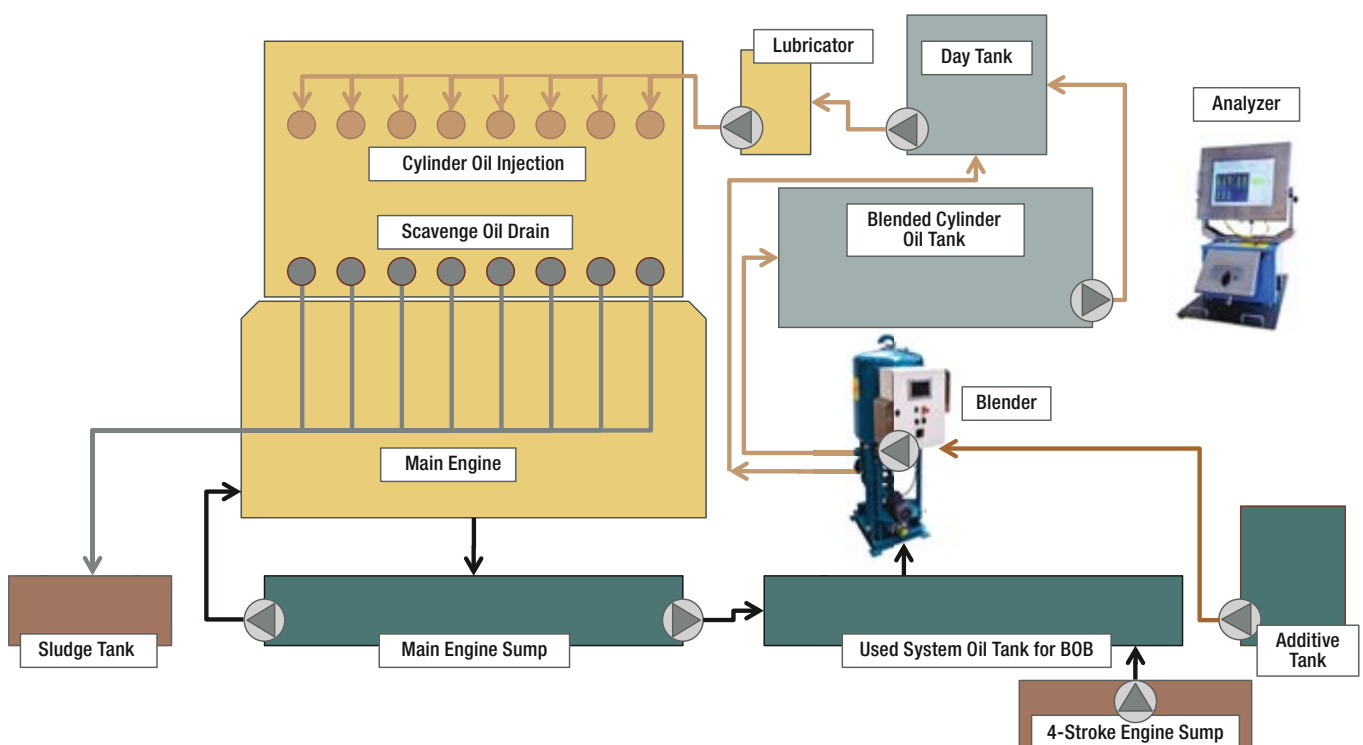

Blender and making the necessary piping and tank adaptations, the total system is commissioned by a senior engineer and the crew is trained to use and operate the blender and analyzer.

Co-operation with Maersk Fluid Technology

The Blending on Board concept and the SEA-Mate® Blender and Analyzer products were invented, designed and patented by Maersk Fluid Technology (MFT), a subsidiary of the A.P. Moeller-Maersk group. Both the concept and the system products have, within the past four years, been installed in 25 Maersk Line container vessels, of which eleven have Wärtsilä two-stroke main engines.

After analyzing the technical feasibility of the Blending on Board concept, and its potential as a new flexible engine lubrication management approach for the market, Wärtsilä and MFT entered into a co-operation agreement in the beginning of 2011 for the joint marketing and sales of the system. An extensive field testing and approval process, for both the system capabilities and the performance of various BN levels of blended cylinder oils with different system oils and additives, was also initiated.

Field test results

Wärtsilä followed the strict and demanding product market introduction process determined for oil applications. This procedure was started by an independent LOQUS laboratory analysis of the blended cylinder oils, and a comparison of the findings with the properties of commercially available cylinder oil products. The laboratory analysis was followed by extensive field testing throughout 2011. Various combinations of blended oils at different BN levels, with different operational loads and different fuel sulphur contents, were tested and the condition of the piston running components subsequently checked. All tests were concluded successfully with very positive impact on the engine operation and cylinder lubrication costs. Different cylinder oil additives from different oil suppliers and many different operational patterns were tested. These field test activities have resulted in numerous "Letters of No Objections" and the full endorsement of the Blending on Board concept and operation by Wärtsilä.

When operated in harsh conditions (high sulphur content of the heavy fuel oil, low engine load leading to lower temperatures, high humidity in the scavenge air, etc.),

two-stroke engines are more prone to corrosion attacking the cylinder liners and piston rings.

To reduce the corrosion, Wärtsilä and other engine designers recommend increasing the cylinder lubrication oil feed rate in order to increase the neutralisation effect. Once the Blending on Board equipment is in use on a vessel, the reduction in corrosion can be achieved by adjusting the BN of the lubricant, and not by increasing the cylinder oil feed rate.

In one of the field tests, it was observed that with the correct BN adjustment, and the blended oil having a high BN level of 105, the maximum corrosive wear was decreased by 48%.

In addition to these effects, a fast recovery of the engine's cleanliness was observed after the introduction of Blending on Board on a 9000 TEU container vessel with a 12-cylinder Wärtsilä RT-flex96C main engine. The majority of the used system oil was replenished with fresh system oil, and the used oil was utilized for the blending of the required cylinder oil. Thanks to the Blending on Board process, the system oil is regularly refreshed, thus keeping the system oil in its optimal condition and the engine components clean.

Furthermore, as regards engine cleanliness, it was also observed that the lifetime of the vital engine components, such as bearings, hydraulic components in the RT-flex system, piston crowns, etc, can be prolonged as a result of running on fresh system oil.

References for Blending on Board

Blending on Board has already been used and extensively field tested for several years on a total of 25 Maersk Line container vessels. Based on the promising results as described above, and the clear benefits as summarized at the end of this article, Maersk Line decided to rollout the concept to another 26 vessels during 2012, all of which are powered by Wärtsilä RT-flex96C engines. Pilot installations for other ship owners and a power plant are also in the pipeline.

Wärtsilä engine lubrication management services

Along with the sole supply and installation of the SEA-Mate® Blender and Analyzer products, Wärtsilä is offering a variety of services and lubrication management concepts in order to meet the different →

■ Table 1 – Detection capabilities and measurement accuracy of the SEA-Mate® Analyzers.

	Fuel Sulphur	Al + Si	Fe	Pb	Cu	V	Ni	Cr	Zn	Ca
M2000	X		X	X	X	X	X	X	X	X
M3000	X	X	X	X	X	X	X	X	X	X
Detection range/ PPM	100–60 K	> 5	0–5 K	0–1000	0–1000	0–1000	0–1000	0–1000	0–10,000	100–50,000

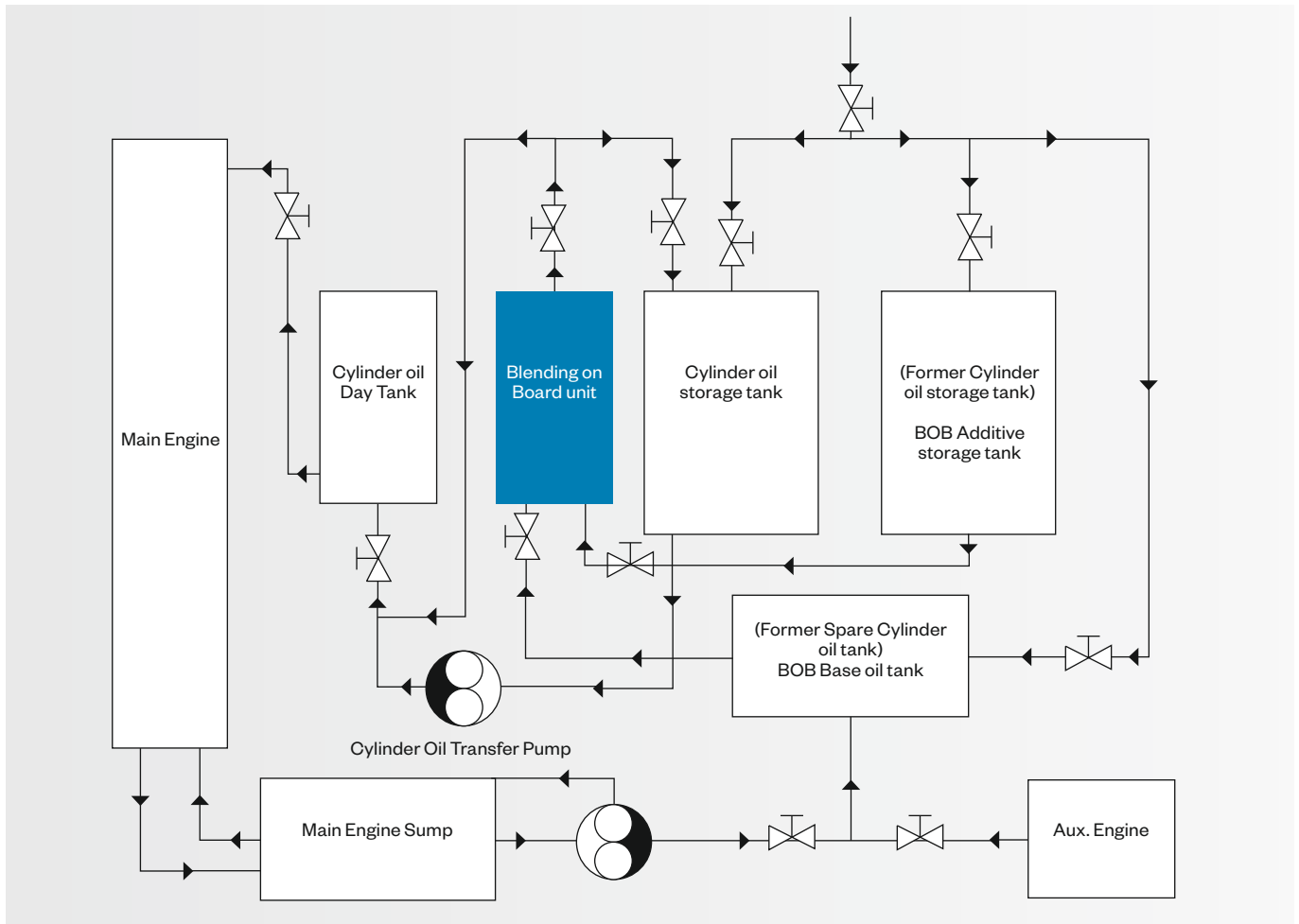

■ Fig. 7 – The layout and flow diagram of the Blending on Board system.

needs and requirements of vessel or plant operators. Some examples include:

- Analysis of an operator's current engine lubrication approach, performance, consumption and overall costs, and consulting for overall optimisation measures
- Analysis of the vessels' piping and tank arrangements, and the design of required adaptations prior to the installation of the Blending on Board equipment
- Blending on Board installation, commissioning, and crew training
- Support for the technical management in implementing the new Blending on Board concept, including assistance in finding the optimal cylinder lubrication feed rate, and managing the overall lubrication performance and costs
- Analysis of trends and special findings, and expert recommendations
- Arranging the supply and supply agreements for system oil and additives

for smaller ship operators

- Full engine lubrication performance agreements, to provide continuous optimisation of the overall lubrication costs.

Flexible concepts

For full operational flexibility of a vessel, Wärtsilä recommends the installation of the complete Blending on Board system, including the blender and analyzer. Depending on the fleet's operating routes, alternative concepts can be decided upon in consultation with the customer. For example, Wärtsilä can also provide on-the-spot analyzing services for regular fuel and lubricants in ports, if vessels are regularly returning to the same port. Or, if vessels are operated on short routes between two ports and always bunkering the same quality of fuel, a "blending ashore" service can be set up by the operator or by Wärtsilä.

"We consider SEA-Mate Blending on Board to be a ground breaking innovation, which will change the lubrication procedure for larger bore engines and bring significant cost savings for the operator. It will reduce cylinder oil consumption by up to 50% and reduce waste-oil volumes by up to 80%. Blending on Board will take ship-owners to the next level in terms of better engine operation, smarter lubrication management, and reducing the environmental footprint."

"With the recent new Maersk Line BOB orders we hope to get the attention of others in shipping, as well as in other onshore industries," says Jens Byrgesen, Managing Director of MFT, who along with technical manager, Henrik Weimar, is driving the product's development and commercialization.

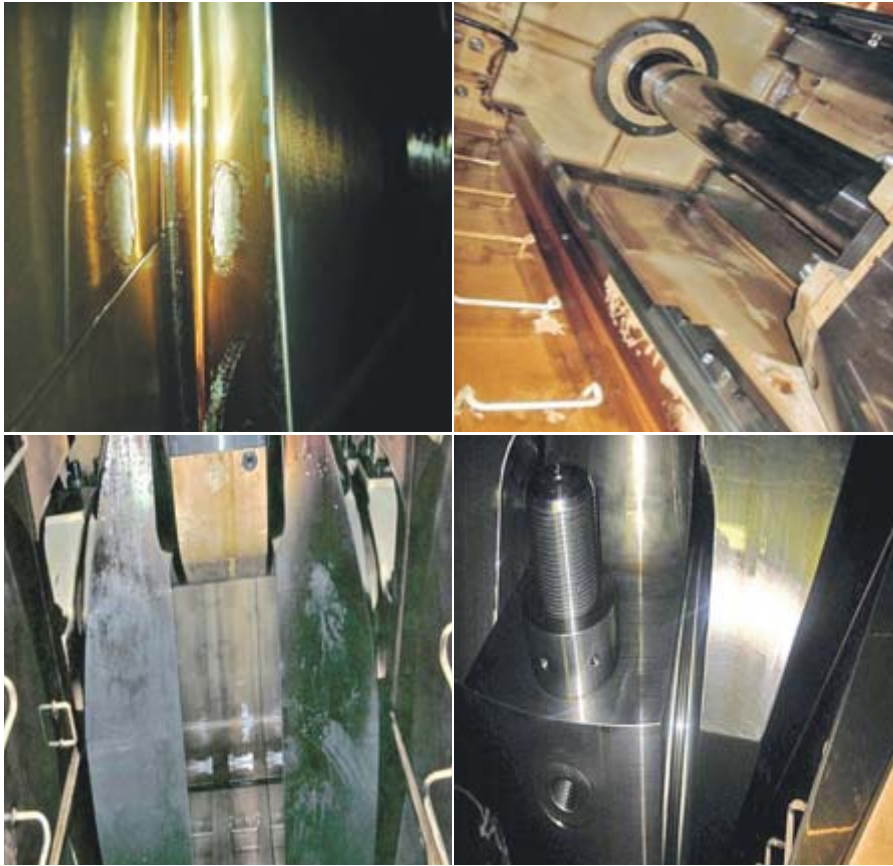

■ Fig. 8-9 – Condition without BOB.

■ Fig. 10-11 – Condition with BOB installed.

Summary of customer benefits

Technical benefits

- Obtaining the optimal constant low cylinder oil feed rate by variable BN blending, matching the fuel sulphur content
→ Just-in-time onboard production of the correct, fit-for-purpose, cylinder oil
- Controlled cylinder liner and rings wear during harsh operating conditions, such as slow steaming
- Engine “cleanliness” and reduction of deposits (crankcase, liners, piston rings, servo) due to the regular replenishment of new system oil in both the main and auxiliary engines
→ Reducing maintenance and the need for oil separator discharging
- Reduced frictional losses with positive effects on fuel oil consumption
→ Up to 1% improvement
- Improved environmental footprint due to reduced lube oil consumption and the reduction of waste oil volumes
→ Lower harmful particulate emissions and up to 80% less waste oil. →

■ Fig. 12 – During a field test on a 12-cylinder Wärtsilä RTA96C engine at different loads, the correct level of BN in the blended cylinder oil resulted in substantial reductions of corrosive wear.

Total Iron content of piston underside drain oil during operation with BOB cylinder lubricant.

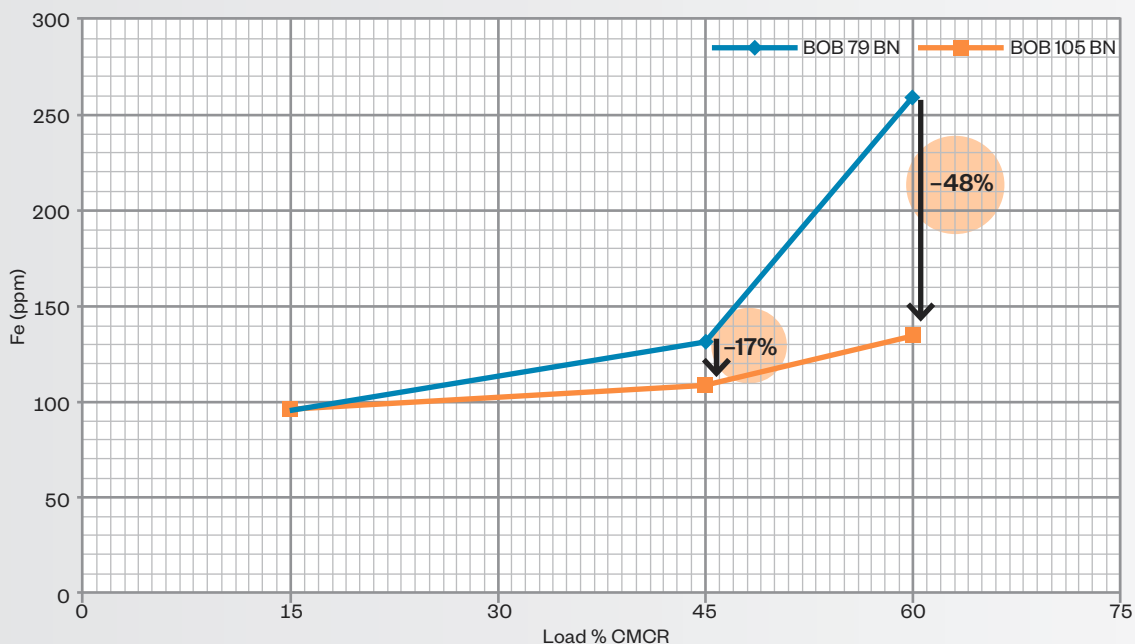

Commercial benefits

- Producing blended cylinder oil from used system oil plus additives results in lower total costs compared to using commercial cylinder oils
- Re-cycling of used system oil, instead of disposing of it, reduces overall lube oil consumption and BN usage
- Less separator discharges, thus additional savings
- Bunkering additives for a longer period of operation creates operational flexibility, as there is no need to buy commercial cylinder oil in expensive ports. Improved supply security by the sourcing of system oil.
- Payback time on investment is usually within 2 years, depending on engine type and operating conditions.

In addition to the overall Blending on Board concept benefits, **the SEA-Mate® Analyzer provides the following benefits:**

- Early wear detection (liner scuffing) with access to wear metal, cat fines (M3000) and BN information
 - Supports the Blending on Board process, feed rate optimisation and TBO extensions
- Analysis of HFO for cat fines and fuel sulphur level (confirm HFO prior to bunkering)
 - Supports the Blending on Board process and operation of the fuel treatment plant
- Analysis results generated in 6 minutes
 - Quick support, reduced external oil analysis costs
- Analysis that includes all lubricated systems (maneuvering systems, ancillaries)
 - Quick support, and reduced external oil analysis costs
- Analysis of used lube oil and fuel oil can be done onboard instead of using

laboratory services

- Reduced external oil analysis costs
- Ability to trace each sample point's history, and to forecast problems by observing trends
 - Supporting professional lubrication management
- Ability to confirm lube and fuel separator efficiency through cat fine measurements (M3000)
 - Support for improved performance, discharges and maintenance can be carried out when needed
- Measurement of key elements (Ca, V, Cr, Fe, Ni, Cu, Zn, Pb, S). Cat fines detection only with the Analyzer SEA-Mate® M3000 tests Si and Al down to 5ppm combined.
- Cylinder oil feed rate reduced to a minimum, thanks to the ability of knowing the true iron wear in the cylinder. The XRF analyzer allows continuous monitoring of various engine fluids, including the analysis of true Fe content; both corrosive and abrasive iron wear. ●

Example of a customer business case

Customer specific business case calculations can be made by providing the customer's installation and operational parameters. The following influencing parameters can be considered in the calculations on a monthly basis: fuel sulphur level, engine load, current used cylinder oil BN, current used cylinder oil feed rate, current price levels for system and cylinder oils:

For the below case calculation, the following parameters were used:

Engine type	7-cylinder Wärtsilä RT-flex96C
Yearly running hours	6000
Cylinder lubrication system (CLU3 or CLU4)	CLU3
Average engine load	50%
Cost standard system oil (USD/t)	1550
Cost standard cylinder oil (USD/t)	2000
Cost additives (BP, XOM, PC) (USD/t)	3500
Cost fuel price (USD/t)	600

Estimated savings and payback times per year with Blending on Board:

Areas of cost savings	Approx. savings in USD/year	Cumul. Savings in USD/year	Payback times in years
Annual savings from cost difference between standard cylinder oil and blended cylinder oil and from reduced feed rate (0.1 g/kWh assumed)	110,000	130,000	<2.5
Annual savings from reduced system oil losses through separator discharging, due to extended discharge intervals	20,000		
Annual savings from reduced maintenance and spare parts costs due to better component condition and TBOs	50,000	180,000	<2.0
Annual fuel savings of 0.5% due to impact of reduced friction and optimal viscosity coming from frequent replenishment of system oil and cleaner engine.	60,000	240,000	<1.5