

Wärtsilä NOx Reducer (NOR)

PRODUCT LEAFLET



Today, new and more stringent legislation concerning NOx emissions is a global phenomenon, and governing bodies like the International Maritime Organization (IMO) are introducing stricter regulations. Additional regulations in the shape of fees, taxes or incentive programmes, are being implemented. Selective Catalytic Reduction (SCR) is today's primary technology for NOx abatement. NOx Reducer is available for all Wärtsilä medium speed engines. Wärtsilä provides IMO and EPA Tier III certificates for the combination of engine + NOR.

In-house expertise for combined system of engine and SCR is an assurance for perfect integration, efficient operation and long time reliability.

Wärtsilä NOR allows a ship to be compliant globally in NOx emission control areas. Wärtsilä provides a IMO Tier III EIAPP certificate for a complete package of engine and SCR.

THE WÄRTSILÄ NOx REDUCER SUITS ALL SHIP TYPES

The Wärtsilä NOx Reducer (NOR) system has been developed with a compact and flexible design for easier installation and maintenance onboard. The Wärtsilä NOR is suitable for both newbuilds and retrofits. Wärtsilä NOR systems are used for a wide selection of applications such as fishing vessels, cruise vessels and gas carriers with dual fuel engines operating on gas, diesel or heavy fuel oil and can be operated together with other exhaust gas treatment units, such as SOx scrubber systems. Furthermore, with the Wärtsilä NOx Reducer, the overall performance of the engine and exhaust gas cleaning system is optimized in terms of emissions reduction, noise abatement, and engine efficiency.

Choosing the Wärtsilä NOR system gives you access to spare parts and worldwide lifecycle support via our extensive global 24/7 service network.

ENGINE ENDORSEMENT, TOGETHER WITH COMPACT DESIGN

The prefabricated auxiliary units (as shown in fig.1) have a compact design. Pump units with redundancy are available, while easy maintenance has been one of the main development targets.

The NOR reactor design is available in a wide range of sizes and shapes. The reactor can be orientated either vertically or horizontally. With the Wärtsilä NOR we provide design options which are optimized to fit any space if it is constrained by width or by length.

With a high level of standardization and modularization, the system has been developed to meet the needs of marine applications. The catalyst elements are validated with Wärtsilä engines and with different fuel oil qualities.

Wärtsilä engines delivered together with an SCR system are equipped with exhaust gas temperature control to ensure sufficient temperature for SCR operation. Temperature control is configured to adjust the temperature set-point according to SCR operational status (ON/OFF) and selected fuel grade.

Integrated engine and SCR control system compensates changing ambient and engine operating conditions. This ensures optimised efficiency and reliability of the whole system. Long term performance of catalyst elements is ensured through having the right engine exhaust gas temperature and efficient soot blowing system on the SCR chamber.

The SCR reactor can also be integrated with silencer and used together with Wärtsilä Compact Silencer System (CSS) in order to further optimise the use of space onboard (as shown in fig.2). For exhaust gas noise attenuation the following options for Wärtsilä SCR system are available:

- Compact NOR: SCR reactor with integrated silencer (absorbitive type)
- Mixing silencer: Urea injection and mixing unit with integrated silencer (reactive type)

NOx REDUCER (NOR) SYSTEM DESIGN

Fig 1. NOR layout showing standard and optional scope of supply.

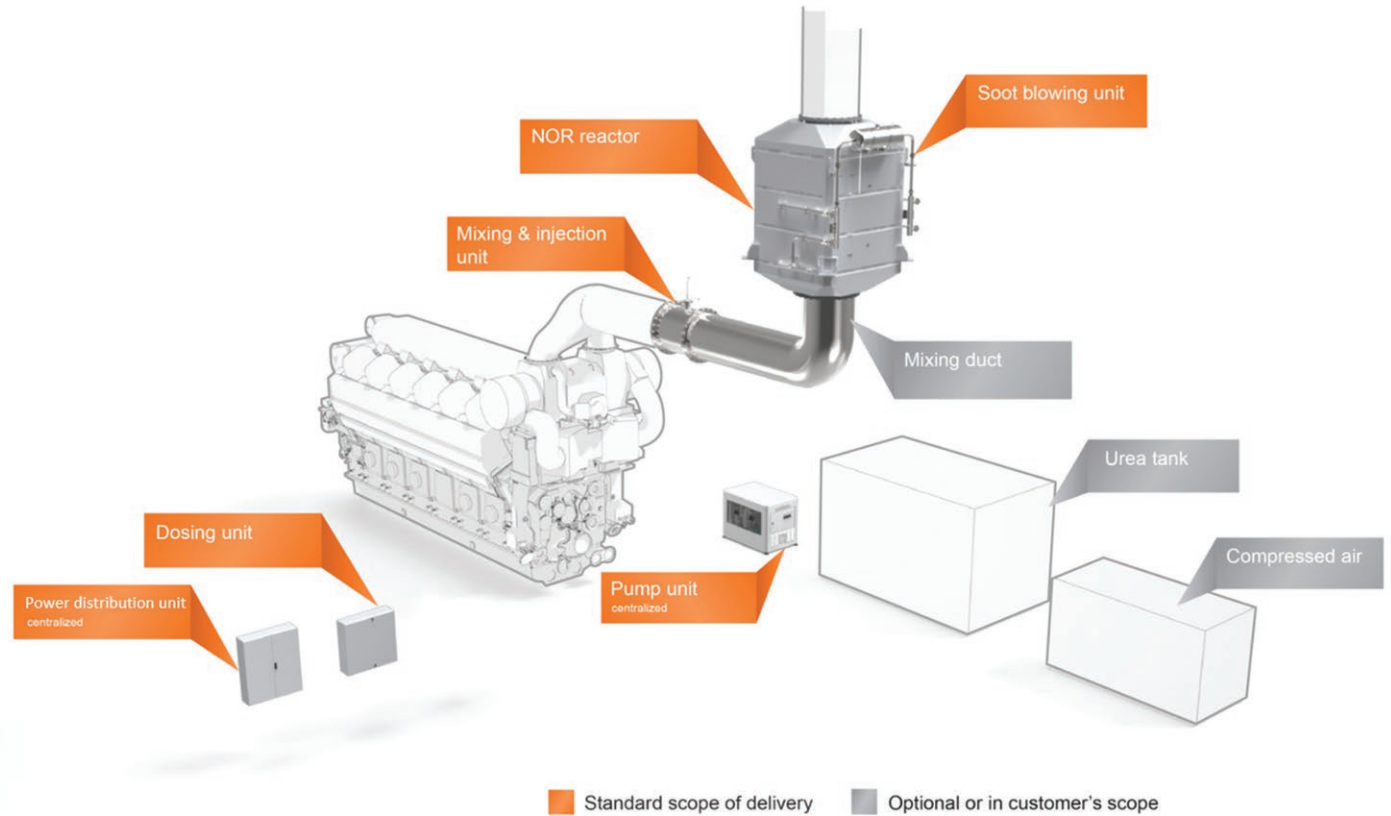
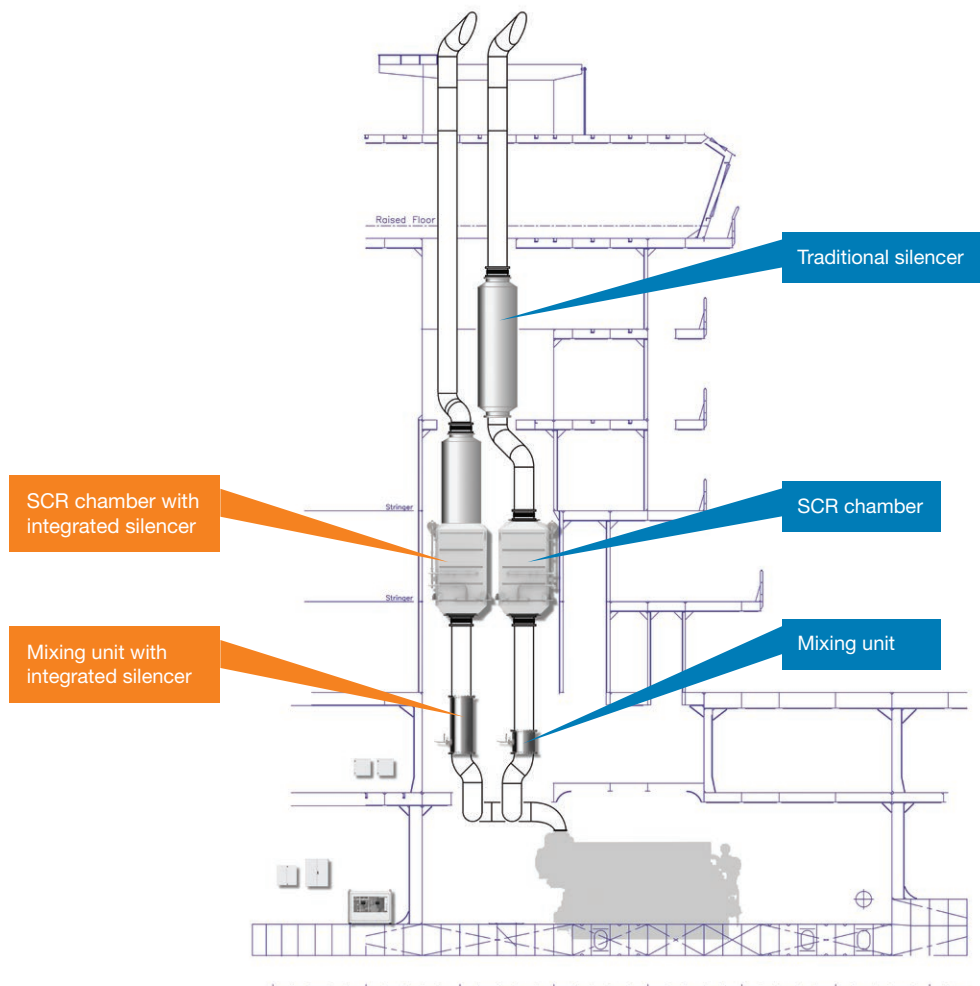

Fig 2. Space saving potential of NOR and mixing silencer arrangement (left exhaust pipeline) compared to standard NOR reactor and conventional silencer (right exhaust pipeline).



NOx REDUCER (NOR) TYPICAL DIMENSIONS

CUSTOMER BENEFITS

Table 1. Example of typical dimensions, 2 catalyst layers reactor

Engine Type	MDF Fuel			HFO Fuel		
	L (mm) (incl. cones)	H (mm) (incl. 150 mm insulation)	W (mm) (incl. 150 mm insulation)	L (mm) (incl. 150 mm insulation)	H (mm) (incl. 150 mm insulation)	W (mm) (incl. 150 mm insulation)
W6L20	2350	1160	1160	2600	1480	1480
W8L20	2500	1320	1160	2700	1640	1640
W6L32	3000	1800	1640	3200	1960	2120
W8L32	3000	1960	1800	3200	2280	2280
W9L32	3000	1960	1960	3300	2440	2280
W8L46F	3300	2440	2440	3600	2920	2920
W12V46F	3600	2920	2920	3900	3560	3560

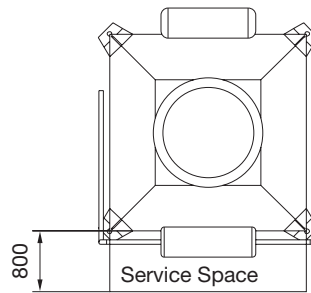
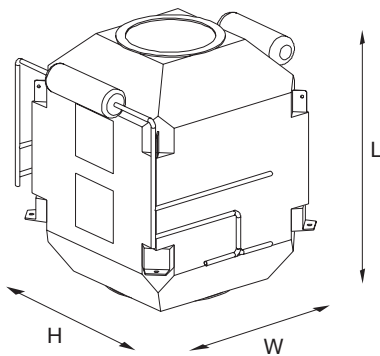
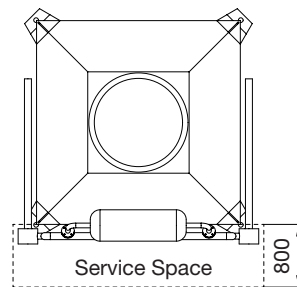
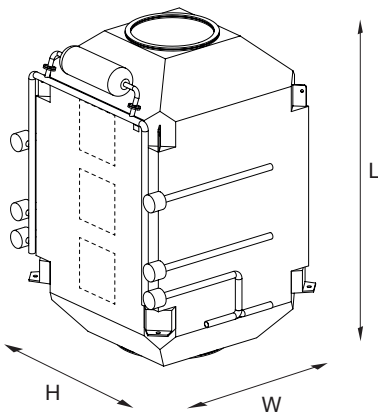

Table 2. Example of typical dimensions, 3 catalyst layers reactor

Engine Type	MDF Fuel			HFO Fuel		
	L (mm) (incl. cones)	H (mm) (incl. 150 mm insulation)	W (mm) (incl. 150 mm insulation)	L (mm) (incl. 150 mm insulation)	H (mm) (incl. 150 mm insulation)	W (mm) (incl. 150 mm insulation)
W6L20	3150	1160	1000	3300	1320	1160
W8L20	3150	1160	1160	3400	1480	1320
W6L32	3500	1640	1480	4000	1800	1640
W8L32	3500	1640	1640	4000	1960	1800
W9L32	4000	1800	1800	4200	2120	1960
W8L46F	4200	2280	2120	4300	2600	2440
W12V46F	4400	2600	2600	4600	2920	2920



Benefits of Wärtsilä's NOx reducer system

- IMO Tier III / EPA Tier III certificate for the combination of Wärtsilä engine + NOR.
- Compact and flexible design for easy installation onboard.
- Optimized and validated with Wärtsilä medium speed engines in terms of reliability and size.
- Durable catalyst elements that withstand ageing and erosion.
- Typical urea (40% solution) consumption: in average operation 10-15 l/MWh, but can be optimized in certain circumstances.
- Typical noise reduction for the NOR reactor: 8-12 dB(A). Possibility to integrate NOR reactor with silencers.
- Fuels: HFO / MDO / MGO. Compatible with SOx scrubber systems and other exhaust gas equipment in the exhaust line.

Aftersales, service & support

Wärtsilä's service network reaches almost all corners of the world. This extensive coverage ensures that plant operators receive fast and effective response to their maintenance needs.

In order to find the best solution for fitting the SCR system we provide our customers with design support and different layout proposals.

Wärtsilä supports its customers throughout the lifecycle of their installations by optimizing efficiency and performance. We offer expertise, proximity and responsiveness for all our customers in the most environmentally sound way.

Our services and support solutions range from basic support, installation and commissioning, performance optimization, upgrades and conversions to service projects and agreements focusing on overall equipment performance and asset management.

We deliver aftersales support through our network of service centres in over 70 countries worldwide.

**SUPPORT THROUGHOUT
THE ENTIRE LIFECYCLE**



www.wartsila.com

NOx@wartsila.com

WÄRTSILÄ® is a registered trademark. Copyright © 2017 Wärtsilä Corporation. Specifications are subject to change without prior notice.



WÄRTSILÄ