

ENERGY
ENVIRONMENT
ECONOMY

AQUARIUS® READY SOLUTION

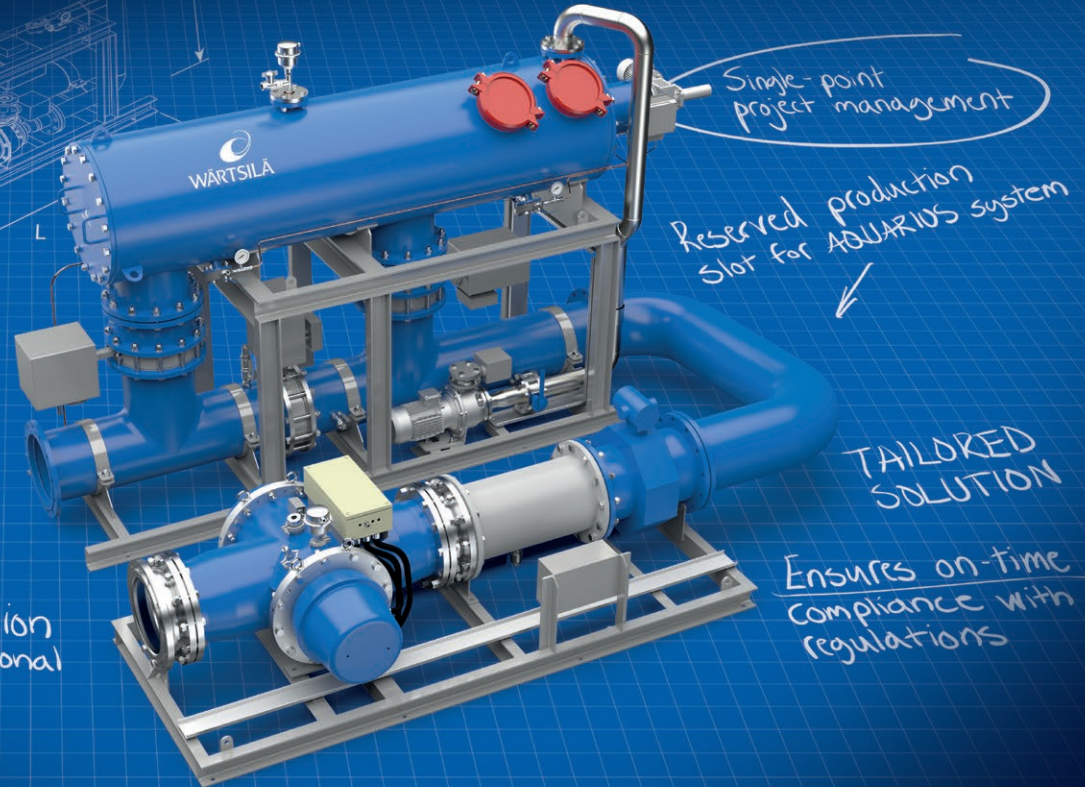

A CUSTOMISED, READY MADE SOLUTION TO REDUCE INSTALLATION TIME AND COSTS

The demand for ballast water management system retrofits is expected to rapidly increase in the near future. In order to avoid potential installation and equipment delivery bottlenecks, Wärtsilä has introduced the AQUARIUS® READY ballast water management solution to ensure a cost efficient and trouble free retrofit.

Wärtsilä offers a choice of ballast water management systems to suit all ship types and sizes, and environmental conditions. The Wärtsilä AQUARIUS® range features a simple two stage process involving filtration and electro-chlorination (EC) or UV irradiation.

The AQUARIUS® READY solution provides the flexibility needed to ensure the timely installation of an efficient process that enables compliance with ballast water regulations.

Wärtsilä's AQUARIUS® READY solution consists of a tailored installation package. The engineering and onboard preparations can be made in advance, and the actual installation of the Wärtsilä AQUARIUS® Ballast Water Management System can be planned as and when required by the ship owner or operator.

BENEFITS

- Tailored solution reduces installation time and costs.
- Phased installation minimizes disturbance to the vessel's operations.
- Reduces risk of congestive system availability and equipment delivery bottlenecks when ratification comes into force.
- By choosing Wärtsilä, ship-owners have a single point of contact, reducing project management costs and risks in coordinating with yards and classification societies.
- Production slot reservation offering for a Wärtsilä system, to stay ahead of the competition and comply to regulations when required.

PRINCIPLE

FEASIBILITY STUDY

The feasibility study is essentially a preliminary design phase needed to determine how to install an AQUARIUS® Ballast Water Management System. The feasibility study includes:

- Ship survey inspection
- Comprehensive feasibility study report

BASIC ENGINEERING

The basic engineering covers all design drawings required for the installation, approval and later production of detailed manufacturing drawings, if required.

ONBOARD PREPARATION & HOTWORKS

The intention behind the onboard preparations is to make all the necessary connections to the existing ballast water system, so that the future BWMS installation will not involve any modifications to the existing ballast water system. This will ensure a faster and more cost effective BWMS installation.

This includes the following:

- Preparation of installation site onboard.
 - New by-pass valve with actuator.
 - New inlet connection with valve and actuator.
 - New outlet connection with valve and actuator.
 - New connection to ballast overboard line.
- All open connections will be blind flanged. The actuator drive can be either hydraulic, pneumatic or electric.

In addition to the mechanical work, Wärtsilä can make all the necessary electrical connection preparations.

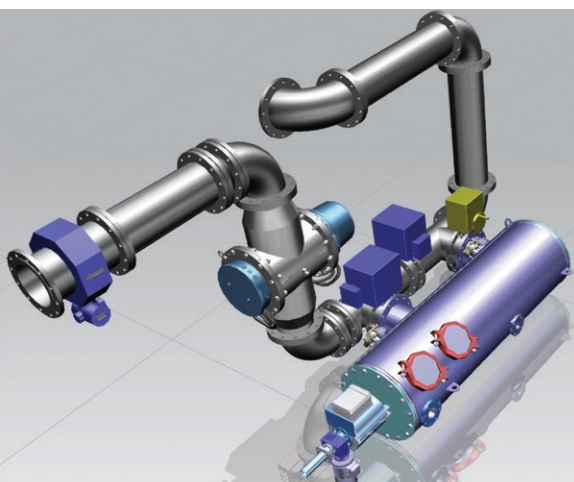

Example of a customised installation

AQUARIUS® READY CONCEPT

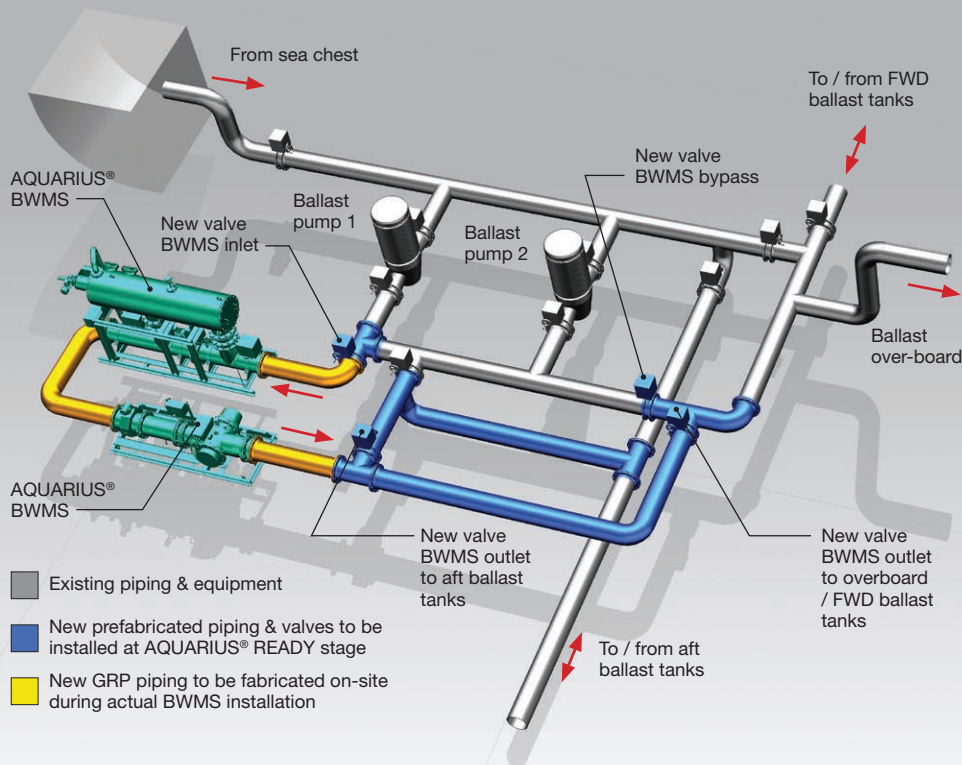

TOTAL BWMS RETROFIT PROJECT

